

INSTRUCTION MANUAL 使用说明书

KM-X2

1/5-SCALE 4WD OFF-ROAD RACING TRUCK



KING MOTOR RACING

Thank You

Thank you for using KM Racing X2! This R/C car is designed to be fun to drive and uses top quality parts for durability and performance. This instruction manual you are reading was designed to be easy to follow yet thorough in its explanations. We want you to enjoy driving your KM Racing X2.



Failure to follow these instructions can damage your R/C car or its accessories, and cause serious bodily injury or death.











Failure to follow these instructions can cause injury to yourself or others.

Caution

- ! To prevent any serious personal injury or damage to property, please be careful when operating all remote controlled models. Extra attention is called for when operating any fuel powered model. These R/C car max. speed can reach 80km/h and use highly poisonous and flammable fuels. Children are forbidden to play below the age of 14.

Safety Guidelines When Operating Gasoline Engines

-  This product uses a mixture of gasoline and two cycle oil for fuel. Please take extreme caution when handling gasoline.
-  Do not run near open flames or smoke while running your model or while handling fuel.
-  Always store fuel in well ventilated place, away from heating devices, open flames, direct sunlight, or batteries.
-  Gasoline is flammable and poisonous. Gasoline powered model engines emit poisonous vapors. These vapors irritate eyes and can be highly dangerous to your health.
-  You must only use a mixture of gasoline and two cycle oil as fuel for this engine. Never use glow fuels intended for R/C cars.
-  Be aware that some parts will be hot after operation. Do not touch the exhaust or the engine until they have cooled.
-  After running, please empty the fuel tank before storing the car.
-  Keep fuel away from children.
-  Store in a well ventilated area.

Components

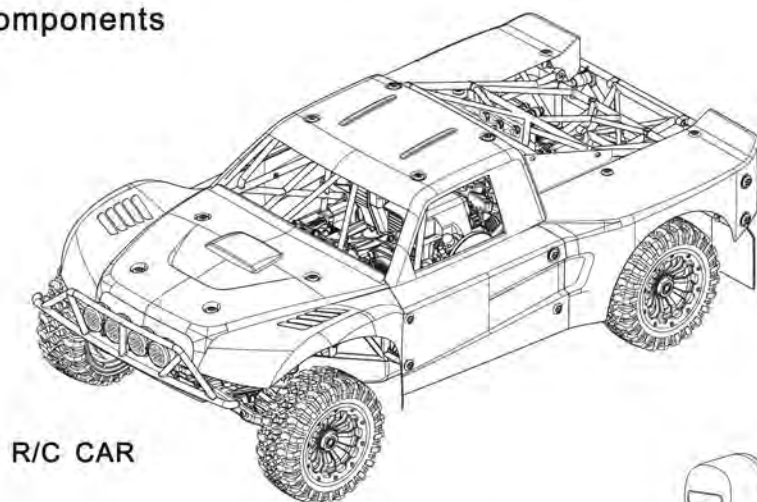

R/C CAR

Battery charger



Transmitter

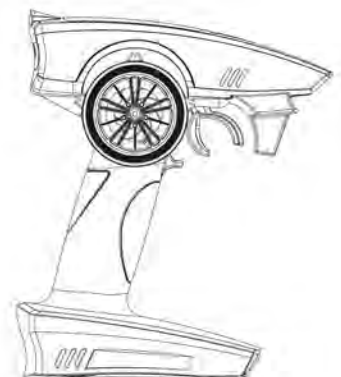

Included Components

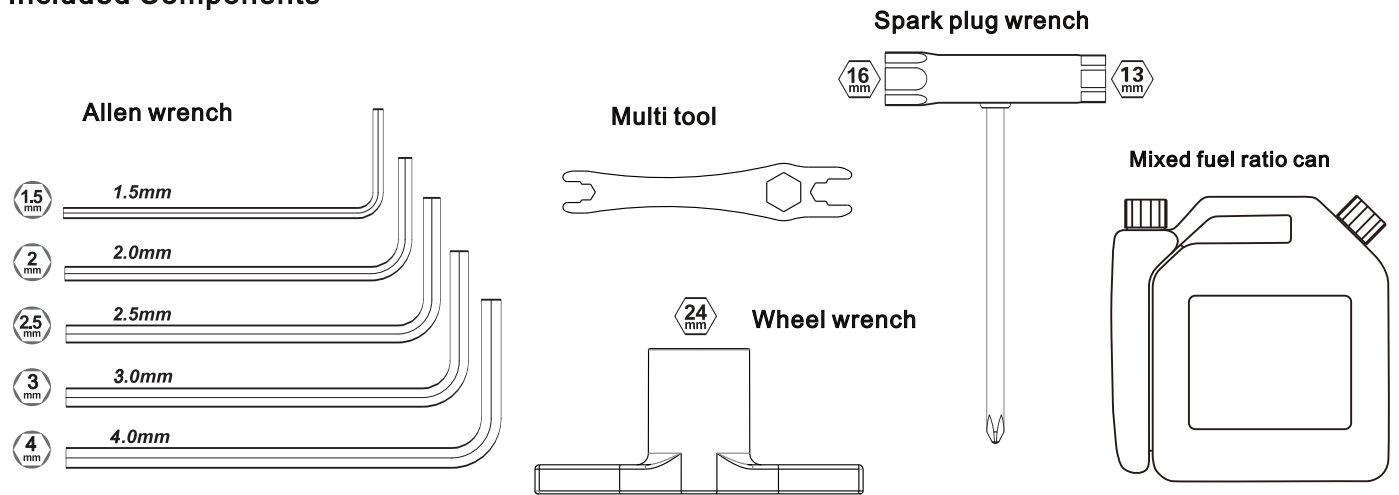

Equipment Needed

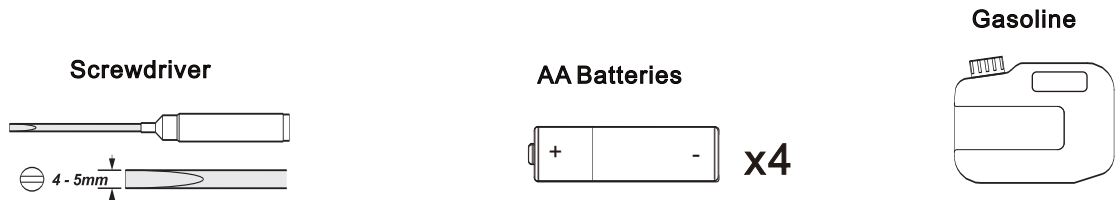

Vehicle Preparation

Remove the body

Remove the 4 screws and 4 body pins

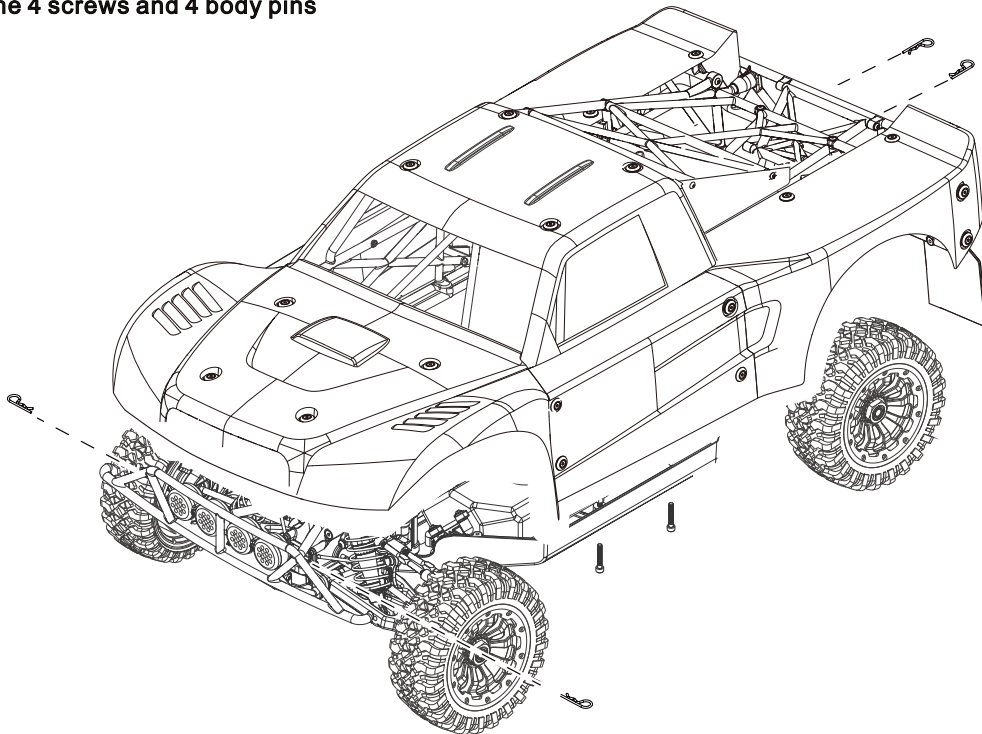

Battery Charging Warnings and Precautions

⚠ Warning: Failure to exercise caution while using this product and comply with the following warnings could result in product malfunction, electrical issues, excessive heat, FIRE, and ultimately injury and property damage.

- Read all safety precautions and literature prior to use of this product.
- Never leave the battery and charger unattended during use.
- Never allow minors to charge battery packs.
- Always inspect the battery for damage before charging.
- Never attempt to charge dead or damaged batteries.
- Never charge a battery if the cable has been pinched or shorted.
- Never allow batteries or charger to come into contact with moisture at any time.
- Never charge batteries in extremely hot or cold places (recommended between 50-80 degrees Fahrenheit /10-27 Celsius) or place in direct sunlight.
- Always use only NiMH rechargeable batteries. This charger cannot charge batteries such as “heavy duty,” “alkaline battery,” or “mercury battery.”
- Always connect the positive red lead (+) and negative black lead (-) terminals of the battery to the charger terminal correctly.
- Always disconnect the battery and charger after charging, and let them cool between charges.
- Always terminate all processes if the product malfunctions.
- Always make sure you know the specifications of the battery to be charged or discharged to ensure it meets the requirements of this charger.
- Always constantly monitor the temperature of the battery pack while charging.
- Always end the charging process if the charger or battery becomes hot to the touch or starts to change form during the charge process.

Charging the Receiver Battery

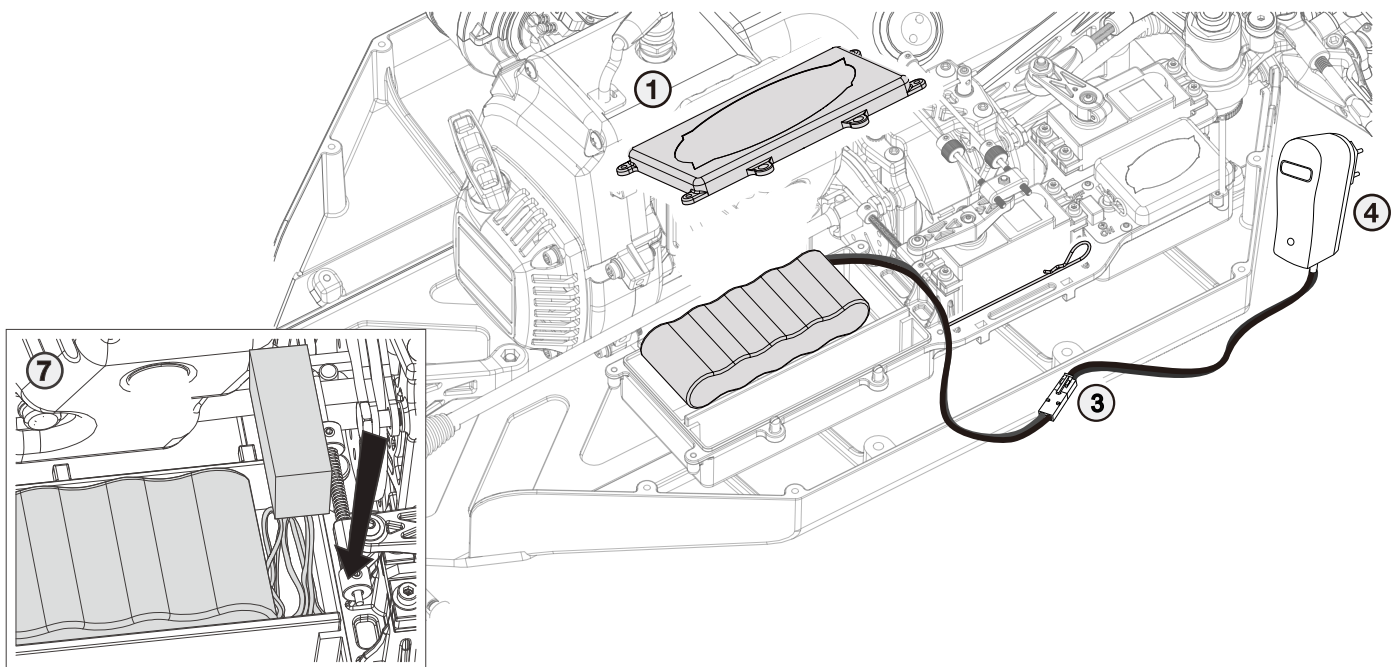

1. Remove the body pin and battery box lid.
2. Remove the receiver battery from the battery box.
3. Connect the receiver battery plug to the battery charger.
4. Plug the battery charger into an AC wall outlet. Charge the battery for 8 hours. DO NOT exceed 10 hour charge time.
5. Monitor battery while charging.
6. When the battery is fully charged: (a) disconnect the battery and (b) remove the battery charger from the wall outlet.
7. Place the receiver battery back in the battery box. The battery wire must be neatly folded in front of the battery and the foam block must be placed on top of the wires.
8. Reinstall battery box lid and body pin.

Transmitter and Receiver

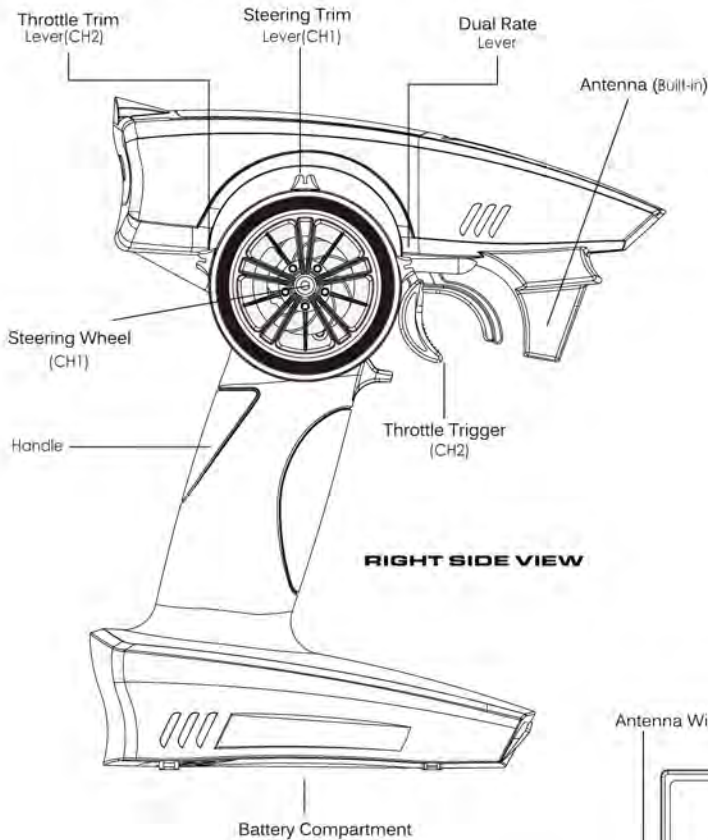

RIGHT SIDE VIEW

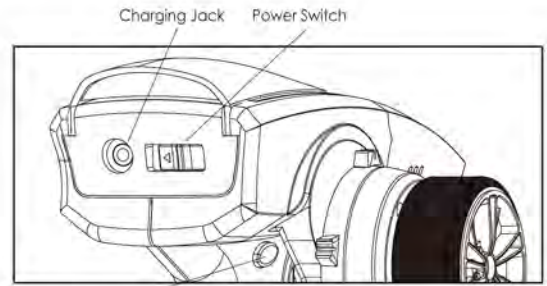

SIDE VIEW

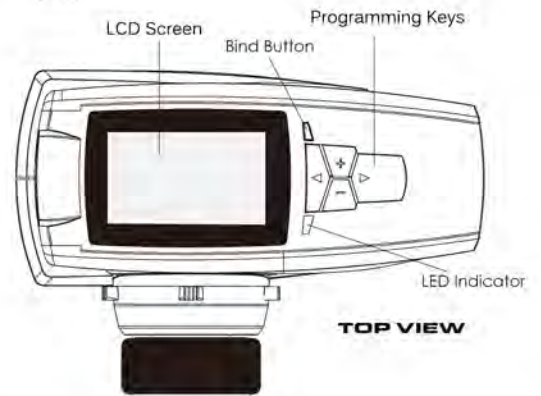

TOP VIEW

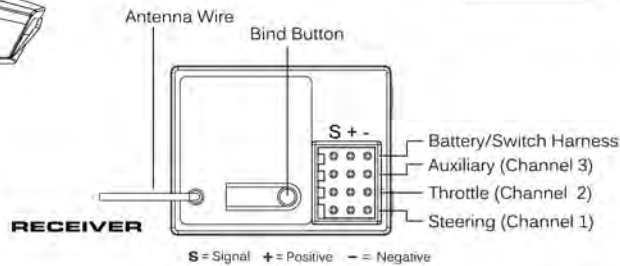

Transmitter Battery Installation

Open battery cover at the bottom of the transmitter. Install batteries. Follow the direction of batteries designated in the inside of battery box.

AA Batteries

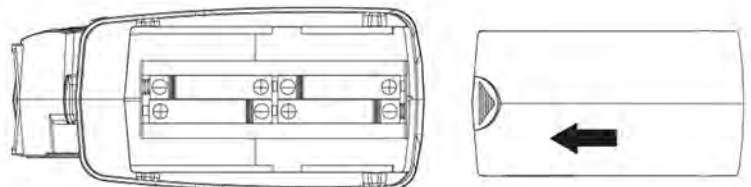

Setup Before Starting

Turn on transmitter first, then turn on receiver.

Make sure no one else is using the same radio frequency as you are using. Check the radio system and range before every driving session. To properly check the range, have a friend hold the buggy with the engine off and walk to the farthest distance that you plan to operate your model. Operate the controls to make sure the model responds correctly. Do not operate the model if there is any problem with the radio system.

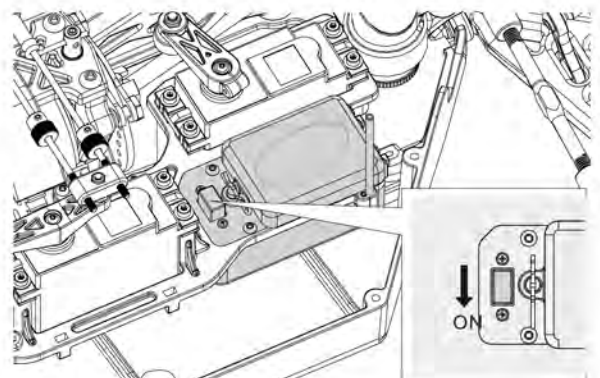
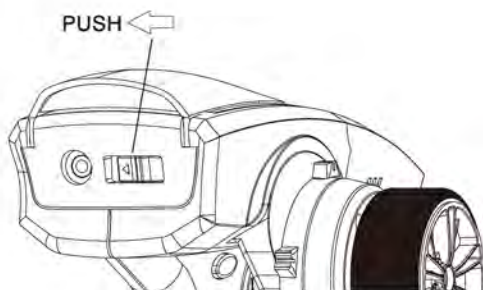

Adjusting Steering and Throttle Trims

Steering Trim

Adjust the direction wheel to center the tires. Use sub-trim (see your remote control's instruction manual) if needed. If direction wheel is not close to its desired neutral position, and direction wheel cannot be centered using sub-trim, please take the following steps:

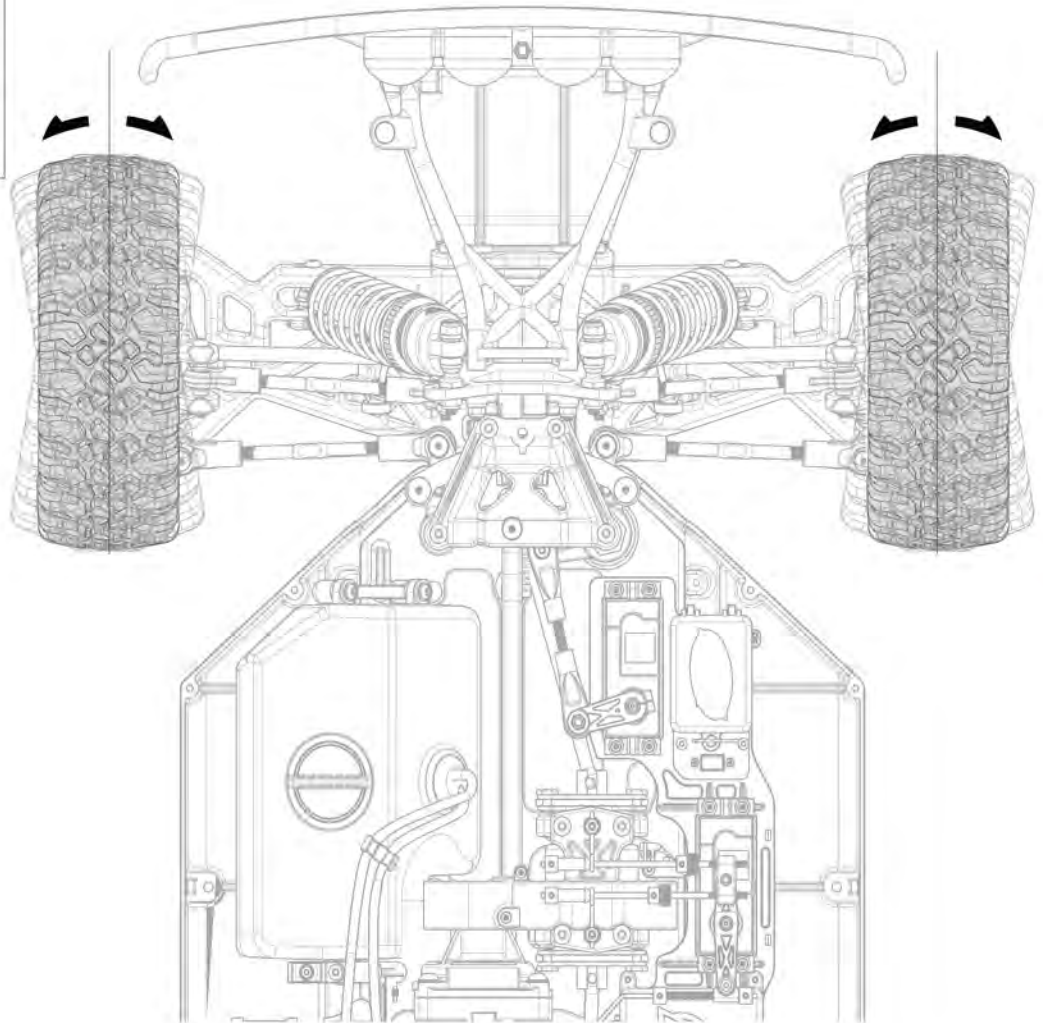
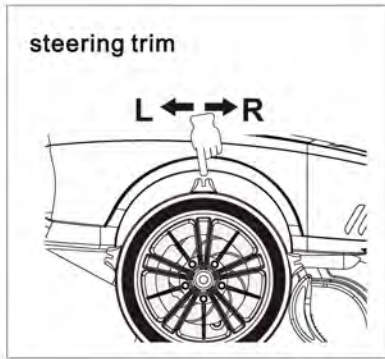

1. Make sure transmitter steering wheel and steering trim are set to "0" or neutral.
2. Remove the servo output rocker arm using a 2.0mm hexagon wrench, exchange angle to install the rocker arm in correct orientation.
3. Trim the steering adjust the steering wheel to the neutral position as described above.

Throttle Trim

Adjust the throttle trim so the carburetor is completely closed at neutral and there is a little gap between the servo rocker arm and collar (Fig. A: gap should be less than 1mm). If throttle rocker arm is not close to its desired neutral position, and throttle cannot be centered using trim, please take the following steps:

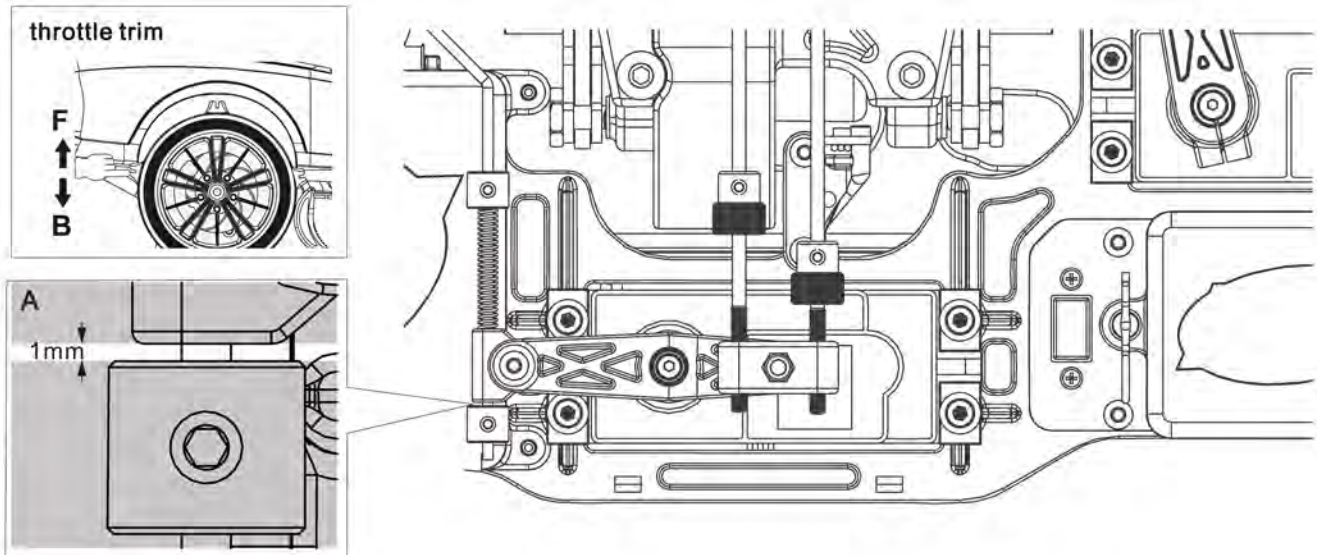

1. Make sure transmitter throttle trim are set to "0" or neutral.
2. Remove the servo output rocker arm using a 2.0mm hexagon wrench, exchange angle to install the rocker arm in correct orientation.
3. Trim the throttle adjust the throttle rocker arm to the neutral position as described above.

Turning R/C Off

Turn off the receiver first, then turn off the transmitter.

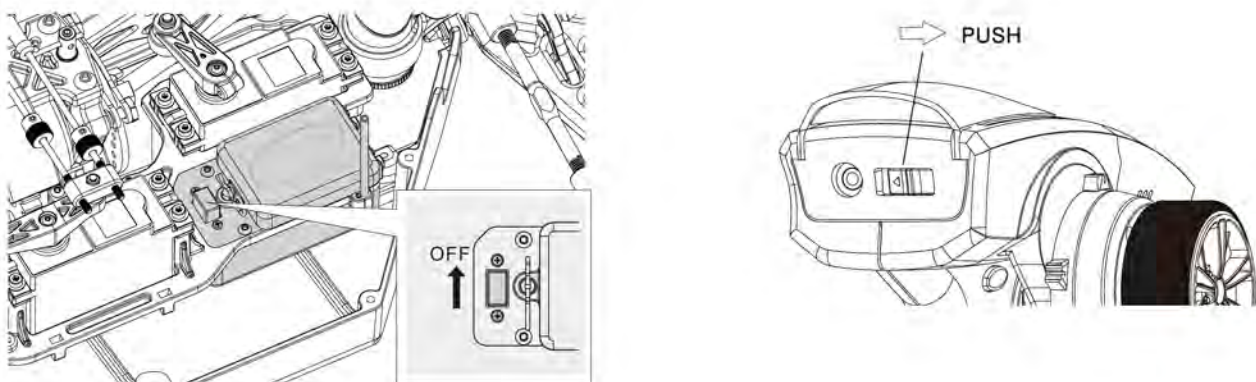

Fuel Preparation

Fuel Warnings and Guidelines

- Always observe all warnings and precautionary statements on fuel.
- Fuel is a fire accelerant. Never operate your vehicle near open flames. Never smoke while operating your vehicle or while handling fuel.
- Always only use a mixture of gasoline and two-cycle oil for fuel. Do not use glow (nitro) fuel.
- Always use caution when handling gasoline.
- Always run your model engine in a well-ventilated area. Model engines produce harmful carbon monoxide fumes.

Fuel Requirement

The fuel is a mixture of gasoline and 2-cycle oil. Use a 25:1 ratio gasoline to oil.

Mixing the fuel

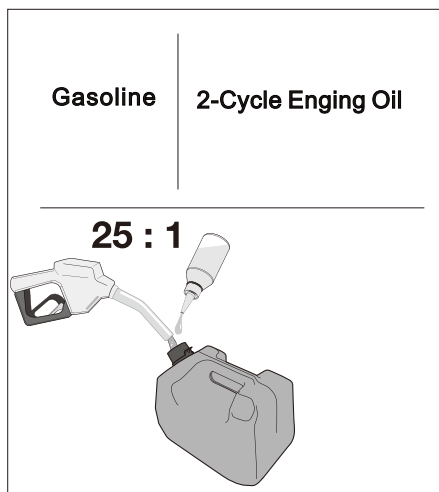

- Always observe all warnings, precautionary statements and instructions supplied by the fuel manufacturer/provider.
- Only use pre-mix two-cycle engine oil. Do not use any other kind of oil.
- Always mix fuel in a sealable, water-resistant container (mixed fuel ratio can) specifically made for gasoline.
- Always blend gasoline with two-cycle engine oil at a 25:1 ratio.
- Never use glow (nitro) fuel.

Fuel Storage Precautions

- Always drain your engine after you have finished running your vehicle. Do not store the vehicle with fuel in the gas tank.
- Don't touch engine and exhaust pipe until they are cooling.
- Always store your fuel in a safe place well away from sparks, heat or anything that can ignite.
- Always ensure that gasoline and fuel are stored in a clearly marked container well away from the reach of children.
- Always store your fuel safely in a sealed, water-resistant container specifically made for gasoline.
- Always store fuel in a cool, dry location.
- Always responsibly discard fuel if there is condensation inside the fuel container.
- Never allow fuel to come into contact with eyes or mouth.
- Never return unused fuel from the fuel tank back into the fuel container.

Transmitter Operation

Steering Wheel

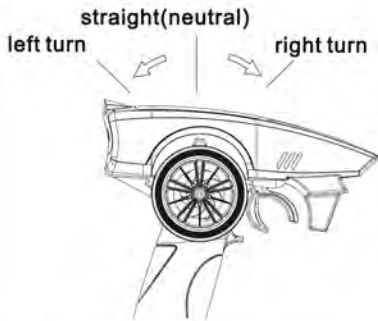

Turning the transmitter wheel left and right will make the front tires of the car do the same. Turning the wheel a small amount will make the model perform a wide turn, Turning the wheel a large amount will make the model perform a sharp turn.

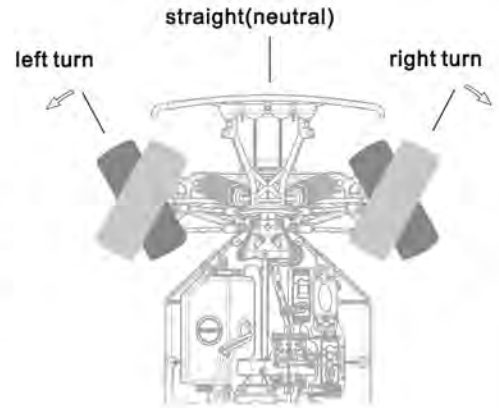

Steering Trim Setup

steering trim

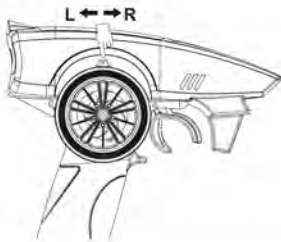

Turn steering trim while driving, that can set the car in the straight line driving.

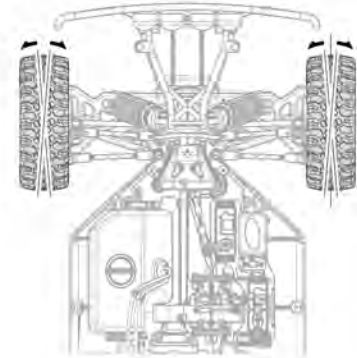

Throttle Trigger

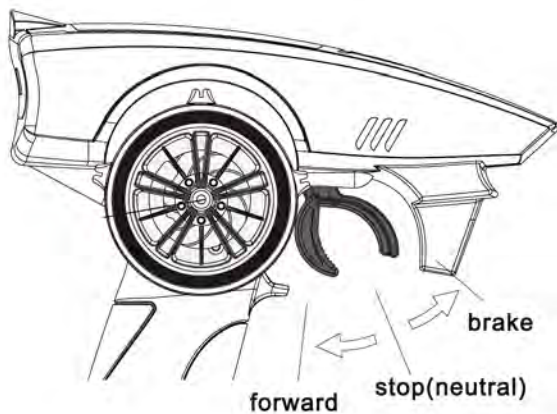

forward

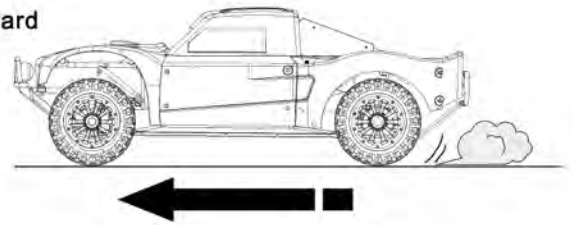

brake

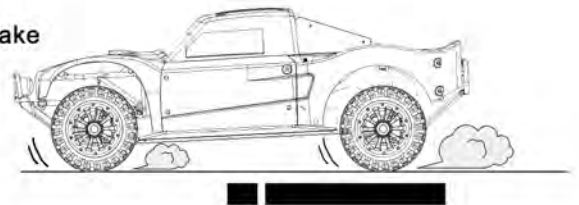

Brake Bias

Standard brake bias is 60% rear and 40% front, If you need more chassis rotation under braking adjust the linkage for less front brake. If the truck is loose entering turns under braking, adjust the linkage for less rear brake or more front brake.

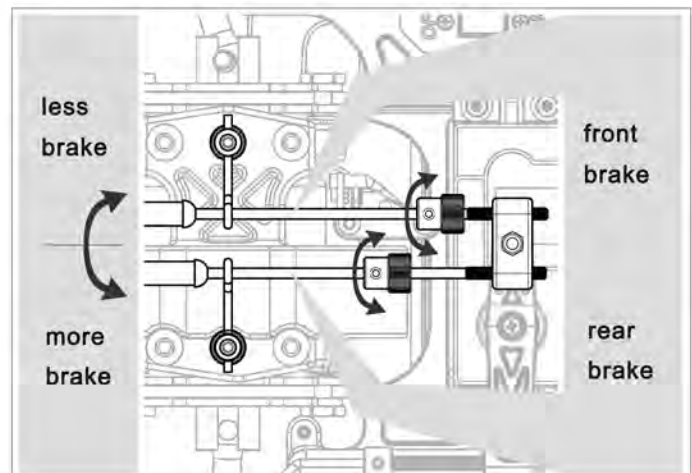

Vehicle starting and Running

Make sure you understand all engine instructions before attempting to start the engine. Failure to follow all instructions can lead to damage to your vehicle, property damage and bodily injury.

Turn on transmitter first then the receiver. If you turn on receiver first, it can cause you to lose control the car. Make sure linkage setup is correct before running.

After running you must check the car and perform routine maintenance.

If there is a problem with the engine, press engine OFF switch to shut down the engine.

Preparation for Engine Start

keep the wheels off the ground

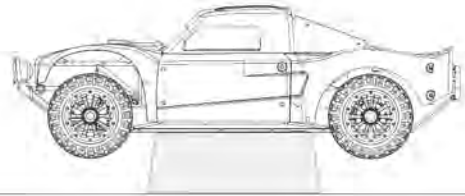

Fill Fuel Tank

Clean the dirt from gas cap before removing. Dirt and debris should never get into the fuel tank. Fill the tank with fuel. Make sure the gas cap is screwed on tightly before starting the engine.

You must use mixture of gasoline and two stroke oil as fuel for this engine, Never use glow fuels intended for R/C cars.

⚠ Caution

Be careful not to tilt the car, gasoline may leak from the vent hole.

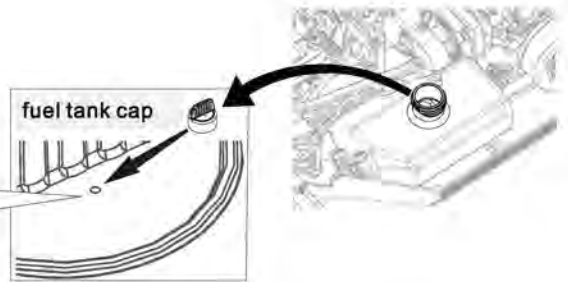

Turn on remote control power

PUSH ←

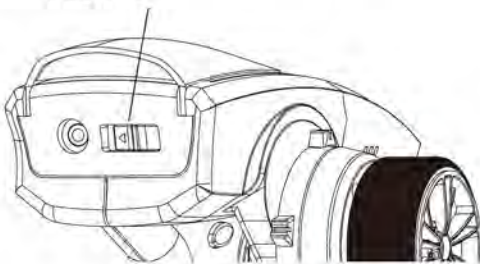

Turn on the transmitter first, then turn on the receiver. Check the throttle and steering function and check the radio range before starting the engine, Make sure no one is using the same frequency.

If you switch on the receiver switch before the transmitter, you may lose control of the R/C car.

Check Max. Range

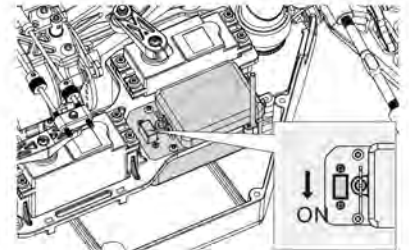

Priming Engine

To prime the engine, fill the tank with fuel and push the primer bulb until fuel appears in the return tube (Yellow). After the engine running for the first time, if fuel appears in the yellow return tube, you do not need to prime the engine.

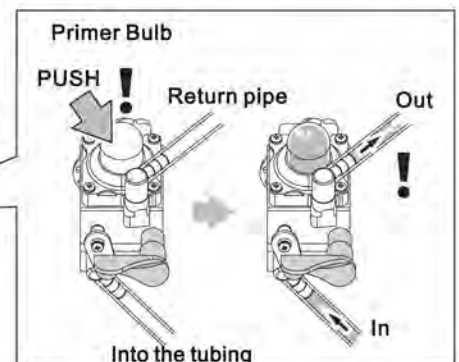

⚠ Caution

If there is a problem with the engine, press engine off switch to shut down the engine.

! Engine OFF Switch

PUSH

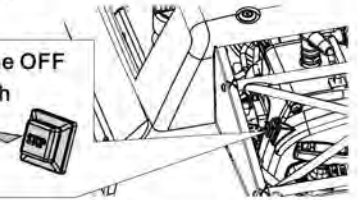

Engine Start

Make sure choke lever is in the horizontal position before starting.

Start the engine by pulling the starter cord in short (No longer than 50cm max.)

The engine should never be run without the air filter in place.

If there is a problem with the engine, press the engine OFF switch to shut down the engine.

Engine Start Tips

1. If you have trouble starting the engine, move the choke lever to the vertical position **A**
2. Pull the starter cord until you hear the engine is almost starting. then move the choke lever back to the horizontal position **B** and try starting the engine.
3. If you pull the starter cord too hard while the choke lever is in the vertical position **A**, you might flood the engine.

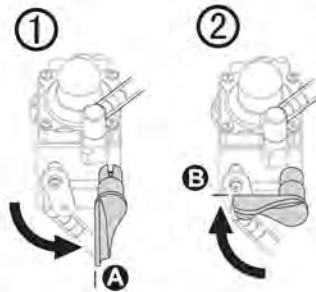
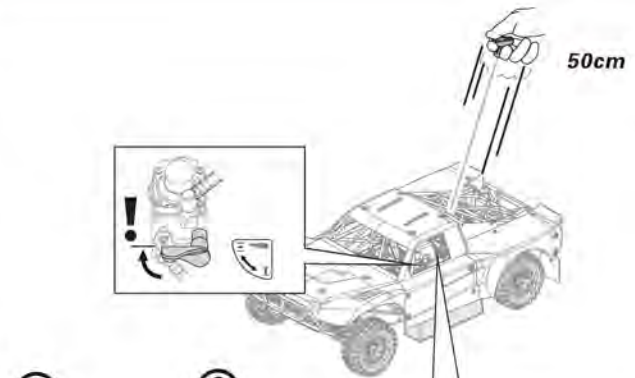

⚠ Caution

Engine OFF Switch

If there is a problem with the engine, press engine OFF switch to shut down the engine.



Breaking in the Engine

Break in the engine by driving slowly for the first half tank of fuel (about 60 minutes).

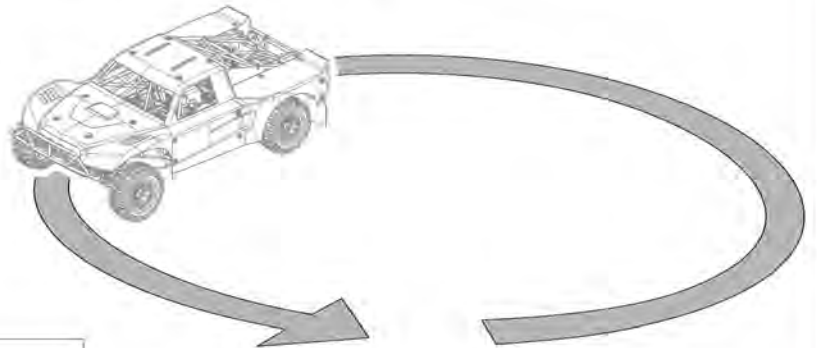

Engine Stop

You can shut down the engine by pushing the engine off switch.

⚠ Caution

Be careful after running, the engine and muffler will be very hot.

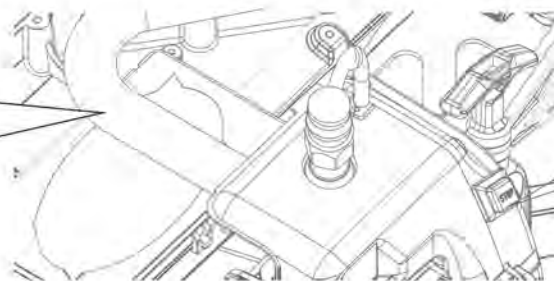

! Engine OFF Switch



Turning R/C off

After the engine is shut off, turn off the receiver first, then turn off the transmitter.

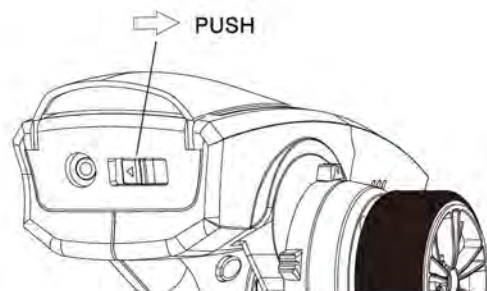
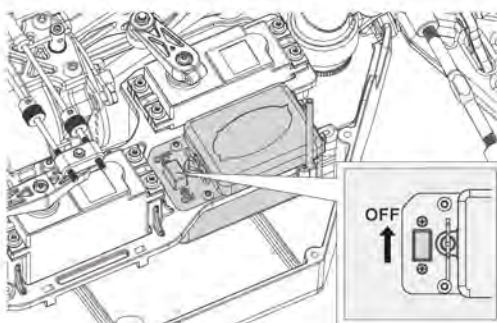

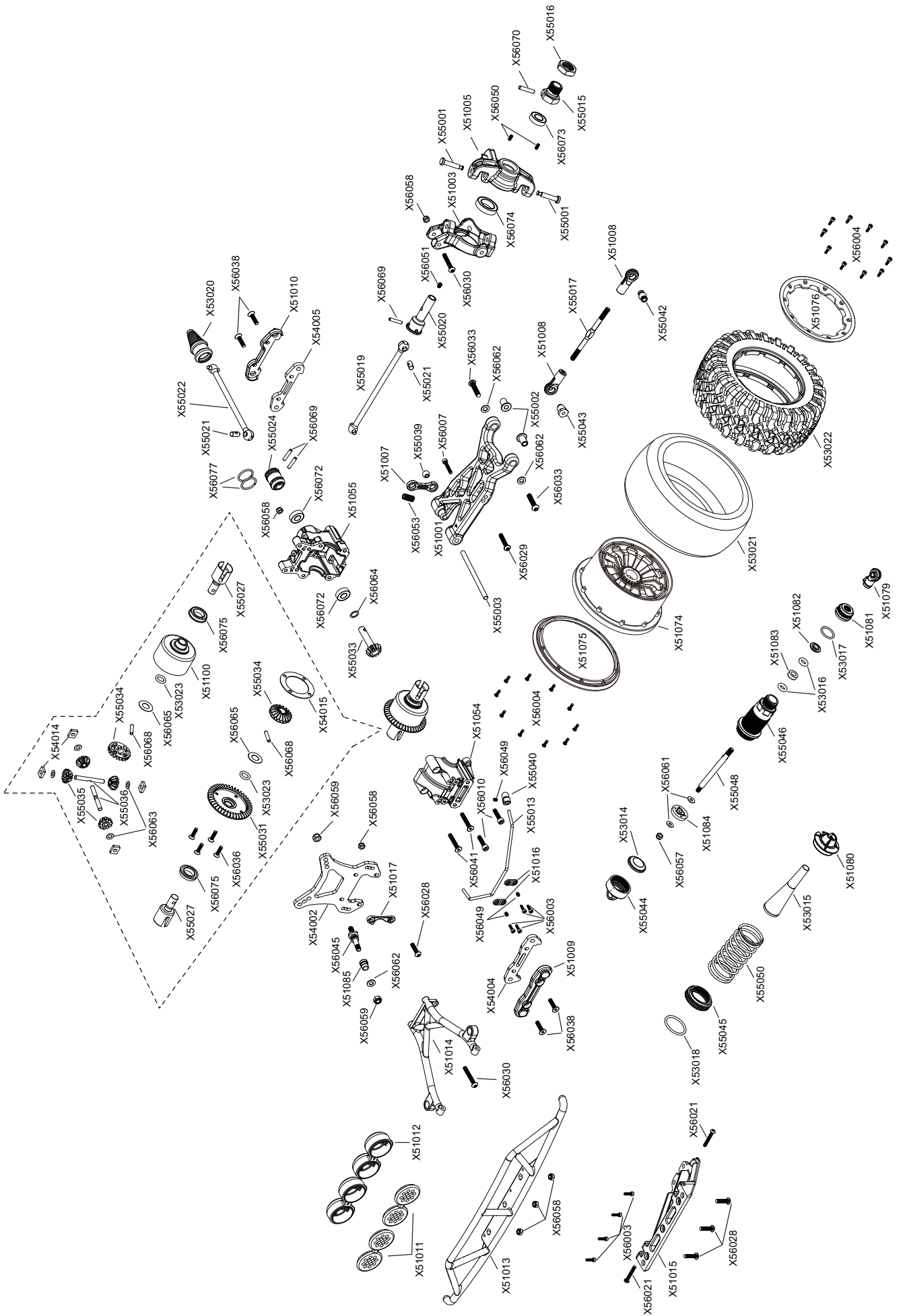

NEW REV 30.5CC GASOLINE ENGINE

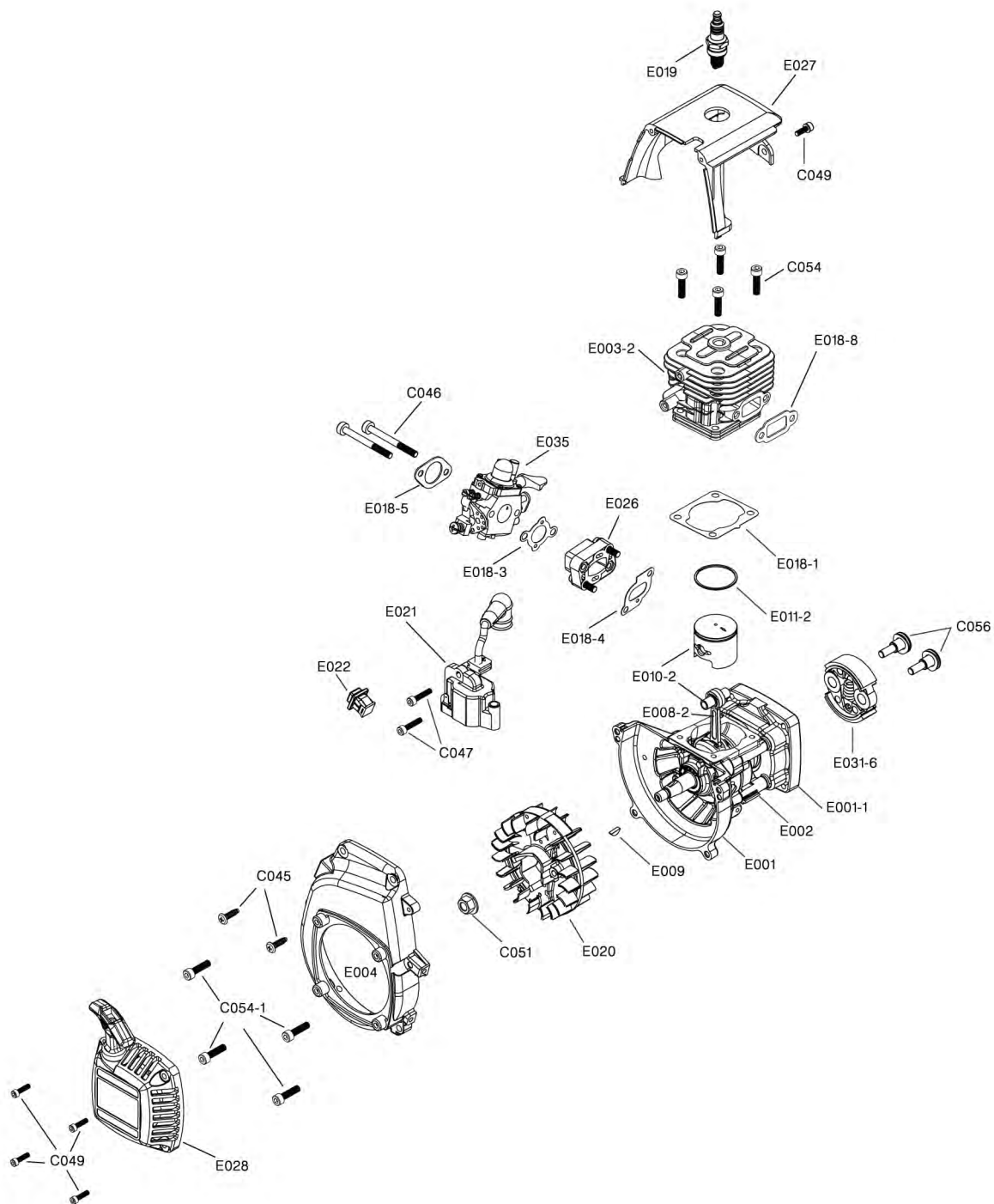



雷神运动器械有限公司

嘉善雷神运动器械有限公司 | 嘉兴市嘉善魏塘工业园区振业路55号

Jiashan Kingmotor Sport Technology Co.,Ltd.

No.55 Zhenye rd,Weitang industrial zone,Zhejiang,China 314100

T/86-0573-84639307 / 0573-84639306

E/sales.frederick@kingmotor.cn

www.kingmotor.cn